

Davidson Traffic Control Products

Available Options for Flexi-Guide® 400/500 Series

Flexible Roadside Delineator Posts



FG Highway Delineator Posts

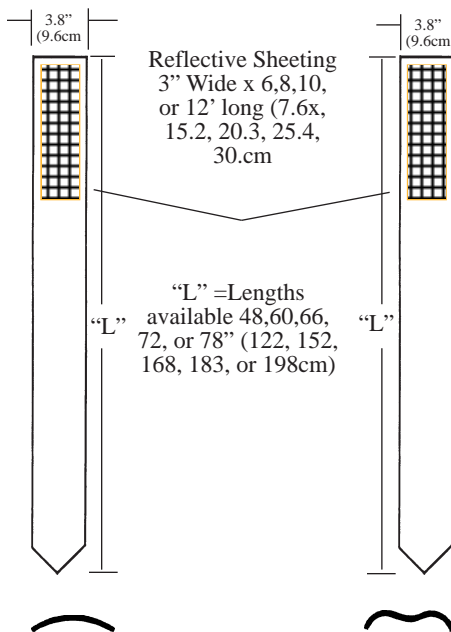

FG 500 series

FG 400 series

Flexi-Guide Posts - are available with a number of standard and special options, including reflective sheeting, message decals, custom colors and length, and various anchors

Reflective Sheeting - Flexi-Guide® posts may be ordered with factory-applied Engineer Grade, High-Intensity or Prismatic Super High Intensity retro-reflective sheeting. Specify type, color, and size when ordering.

Message Decals - Flexi-Guide® posts may be ordered with factory-applied Message Decals, such as "Buried Cable - Do Not Dig!" Call for details regarding availability of standard decal and custom print options.

Custom Colors and Lengths - Standard Flexi-Guide® colors are White, Yellow, and Grey. Other colors are available on a special order basis. Flexi-Guide® Posts can be cut to any length you desire.

Anchors - Flexi-Guide® posts may be supplied with or without plastic or steel anchors. If anchors are required, specify either plastic or steel when ordering.

Flexi-Guide Anchors

FG 95 Plastic Anchor
all purpose

FG 96 Steel Anchor
for more challenging soils

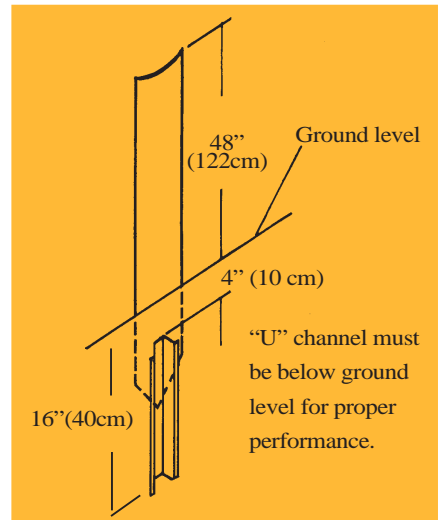
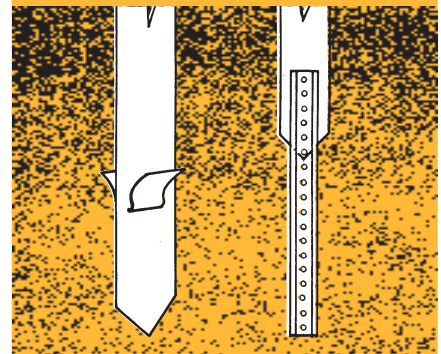

Specifications for Flexi-Guide[®] 400/500 series

Flexible Roadside Delineator Posts



GENERAL: Flexible delineator posts shall be produced from recycled engineering thermo plastics.

CONSTRUCTION: All delineator posts shall be manufactured in the U.S.A. The post shall be made with a minimum of 5% post-consumer, engineered recycled thermoplastic, with the total recycled content being greater than 50%. Post will be modified with virgin modifiers, pigments and UV stabilizers for outdoor weatherability. Posts shall be one color plastic throughout and have a solid plastic profile without fillers.

LENGTH: Post shall be at specified length plus or minus .250 (6.35mm)

REFLECTIVE SHEETING: Shall be of a specified grade and size affixed to the post by the manufacturer.

FG 95 ANCHOR: The plastic anchor shall meet the same physical properties as delineator posts, shall be 2.0" (50.8mm) in length, and of sufficient strength so as to resist pull out in multiple high speed impacts. Anchors shall be placed in slots at the bottom tip of posts prior to installation.

FG 96 STEEL ANCHOR: The steel anchor unit shall be a hot rolled rail steel or new billet steel meeting the physical requirements of ASTM A499 and the chemical requirements of ASTM A1.

CONSTRUCTION: The steel anchor shall be a uniform flanged channel post with nominal weight of 1.12 #/ft. (.418 kg) before holes are punched. Anchors shall be 12" or 18" (457.2mm) in length and have a sufficient number of 3/8" (9.5mm) diameter holes on 1" (25.38mm) centers to facilitate attachment of flexible guide posts. Anchors shall be supplied with attachment hardware as recommended by the manufacturer.

Posts shall satisfy the following typical properties

PHYSICAL PROPERTIES	RESULTS	ASTM
Specific Gravity,	1.20 (Typ)	D792
Water Absorbtion, 24 hrs, 73F	.576	D570
MECHANICAL PROPERTIES		
Tensile Elongation at break	30% Min	D638
Rockwell Hardness R-Scale	100 Min	D785
IZOD IMPACT		
1/8" Notched (ft. lbs./in.)	12.0 Min	D256
1/8" Unotched	No Break	D256

RECYCLABLE / RETURNABLE:

Flexible posts will be recyclable by the manufacturer. Posts that become damaged under normal use will be returned to the manufacturer, reground the reused to make other delineation products. The manufacturer will offer credit toward the next purchase when products are returned.

Important Notice To Purchaser

The following is made in lieu of all warranties, expressed or implied, including the implied warranties of merchantability and fitness for purpose: Seller's and manufacturer's only obligation shall be to replace such quantity of the product proved to be defective. Before using, user shall determine the suitability of the product for its intended use, and user assumes all risk and liability whatsoever in connection therewith. Neither manufacturer nor seller shall be liable either in tort or in contract for any loss or damage, direct, incidental, or consequential, arising out of the use of or the inability to use the product.

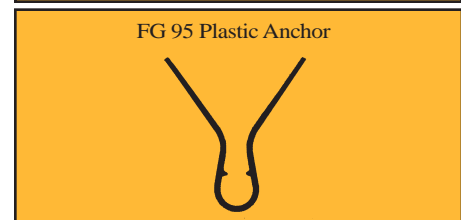
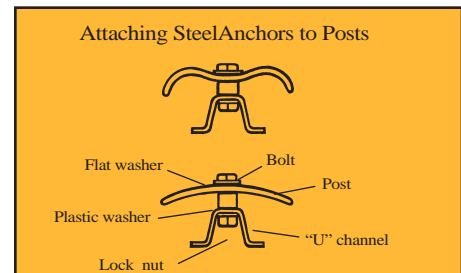

U.S.PAT. 5,028,166



"new name, same great company"

3110 70th Avenue East / Tacoma, WA 98424 / (253) 284 8000 Fax (253) 284 8080
e-mail: hwysales@bunzltacoma.com / web address: www.bunzltacoma.com

Authorized Dealer