

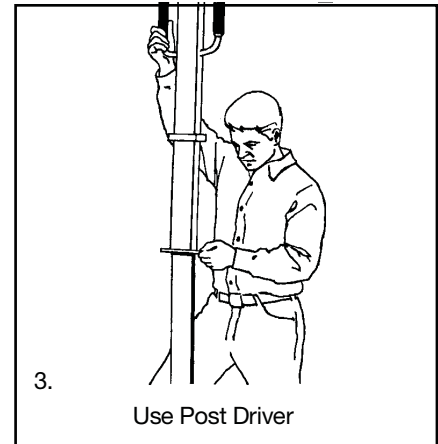

Davidson Traffic Control Products

Instructions for use of **FG 102 System**

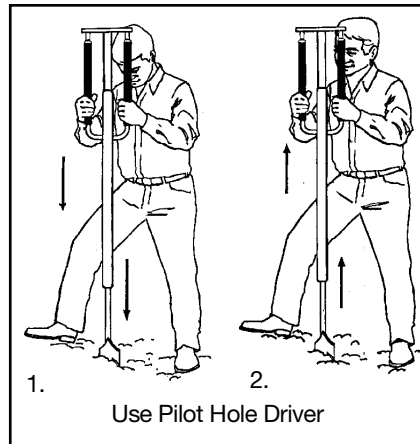
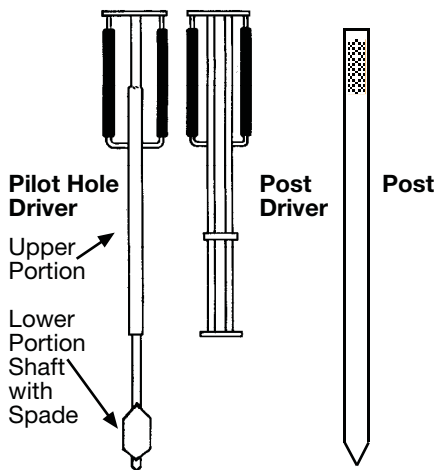

Using the FG 102 Pilot Hole Driver and FG 102 Post Driver

1. Place spade end of FG 102 Pilot Hole Driver at desired point of entry. Grasping the handles located at the top of driver with both hands, slide the upper portion of the driver up and then downward with force sufficient to drive the spade end into the soil. Repeat until spade end and shaft is totally submerged in soil, approximately 18 inches.

2. The Pilot Hole Driver can be removed from the soil by again sliding the upper portion of the Driver up and down, this time creating impact at the top of the Driver. Repeat until entire unit is

dislodged from the soil.

3. Place the post (with anchor placed into anchor slot, if anchors are being used) into Post Driver.

Picking up the entire unit (Post Driver with post inside), place the tip of the post into the pilot hole. Slide the Post Driver up a few inches and then drive down onto the post. This usually can be accomplished without a great deal of force. (Pressure on the downstroke can also be increased, if desirable, after post is at mid-point into pilot hole.) Repeat until post has been driven to full 18" depth.

Alternative Installation Methods for the FG 400 & 500 series

delineator posts include various mechanical systems. Auger installations have proven to be effective and efficient methods. A four-inch auger is recommended. The auger shall be positioned at the hole location, auger a hole to the proper installation depth, typically 18 inches. The post face shall be aligned such that it is perpendicular to traffic flow. The post hole area must then be backfilled and tamped as necessary. Power driver tools also may be used in lieu of the pilot hole driver. Using a power tool with a spade can save time and labor when driving pilot holes.



"Creating Products to Save Lives"



Instructions for use of FG103 Post Driver & FG100 Power Tools

FG 103 Post Driver

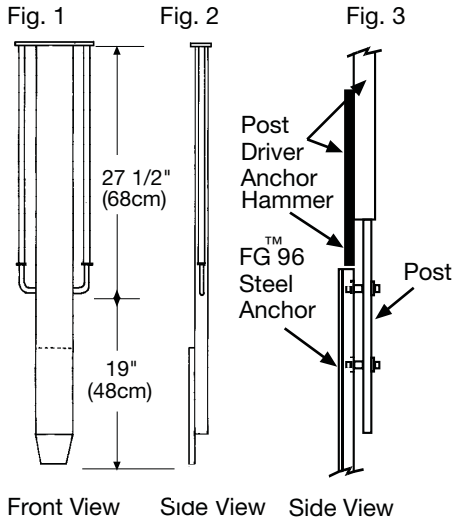

FG 103 up and down, striking the anchor hammer against the top of the steel anchor.

3. Repeat the process until the post is driven to the proper burial depth.
Flexi-Guide 400 & 500 Series delineator posts with 12" and 18"

U-Channel Anchors can be installed using various power driver tools including gas-powered, pneumatic and electric demolition hammers. By simply attaching the fitted tool to your power driver, you are ready to decrease installation time and increase your crews efficiency.

2. At the installation location of the delineator, loosen and remove the top 2-3" of soil (approx.. 5" diam.) with a shovel or power tool. It is important that the top of the U-channel anchor is driven 2-3" below the ground surface

3. Fix the end of the fitted tool on top of the U-channel anchor. Align the face of the post perpendicular to traffic flow. Drive U-channel anchor until it is 2-3" below the ground surface. Ensure post is kept as vertical as possible. Backfill and tamp the area around the post as necessary.

Using the FG 103 Post Driver with FG 96 Steel Anchor (SA)

The FG 103 is designed for use with a steel U- channel anchor. It eliminates the need for a pilot hole and allows the post to be driven into compacted or rocky soils.

1. Place delineator post with steel anchor attached into the FG 103 Driver (See Figure 3).

2. Holding the FG 103 with the post inside, position the steel anchor at the desired installation location. Ensure the post is vertical and front face is perpendicular to traffic flow. Grasp the handles and slide the

The FG 104 is a simple chisel/fork with a 3/4"hex, 5/8"hex spline-shank for use with various driver types.

The FG 105 is a solid one- piece fitted driver head with a 7/8"hex shank. Custom shanks are available to fit various driver types.

FG 106 is a two-piece tool; separate fitted driver head and tamper rod with custom shank for use with various driver types.

1. Select the proper driver tool for your equipment. Custom tools are available, contact your local sales representative for more details.

Call your factory representative for technical questions and support.

