



Davidson Traffic Control Products

# Flexi-Guide® FG 400 & 500

Flexible Roadside Delineator Posts



*"Creating Products to Save Lives"*

left: FG 466  
right: FG 566

## Davidson roadside delineator posts increase visibility and improve safety

### **Flexi-Guide roadside delineator posts save lives by deterring dangerous auto accidents.**

In all kinds of weather, Flexi-Guide posts are highly visible, day and night. Flexi-Guide posts clearly delineate the edge of the roadway with bright reflective sheeting mounted on the posts at the driver's eye level. To reduce the risk of fatal traffic accidents, Flexi-Guide posts can be placed at critical points along the roadway; winding curves, near intersections, on and off ramps, and to identify safety hazards in general.

### **Flexi-Guide is the first post to exceed field performance standards using recycled polymers!**

With concern for our environment, we were the first to engineer our high performance formula using engineering thermoplastics, and in two configurations to meet the challenges of various soils, climate and traffic control requirements. The Flexi-Guide formula gives you extended outdoor weatherability and provides superior strength, flexibility, and chemical resistance.

### **Since 1989, Flexi-Guide Posts have withstood the tests of time.**

Field tested since 1989, our specially engineered polymer formula has demonstrated that it is highly resistant to UV deterioration and has proven its toughness and longevity in severe environments across the nation.

### **Both designs withstand multiple high-speed impacts.**

With their superior strength and flexibility, our patented FG400 Series double curve configuration and our standard curved design of the FG500 Series both can withstand high speed punishment. They also offer better protection of the reflective sheeting upon impact and better visual guidance for the motorist from various angles of approach.

### **Versatile Flexi-Guide posts meet nationwide specifications.**

Order Engineering Grade, High Intensity, or Super High Intensity sheeting for superb night time visibility and to meet various state specifications. Order posts in various colors and lengths, with or without soil anchor systems.

Custom orders can include custom colors, message decals, and steel U-Channel anchors.

### **Get both safe and "green" protection with Flexi-Guide.**

Flexi-Guide posts maximize road safety and minimize long-term maintenance costs. Made of recycled materials, Flexi-Guide posts are part of our Buy Back program that gives you a cost-effective replacement plan and lets you recycle old, damaged posts into new units.



*Flexi-Guide products are both Recycled and Recyclable*



**Davidson Traffic Control Products**

*"Creating Products to Save Lives"*

3110 70th Avenue East • Tacoma, WA 98424 / (877) 335 4638  
e-mail: hwysales@pexco.com • **DavidsonTraffic.com**





Davidson Traffic Control Products

# Available Options for Flexi-Guide® 400 & 500 Series

Flexible Roadside Delineator Posts

## FG Highway Delineator Posts

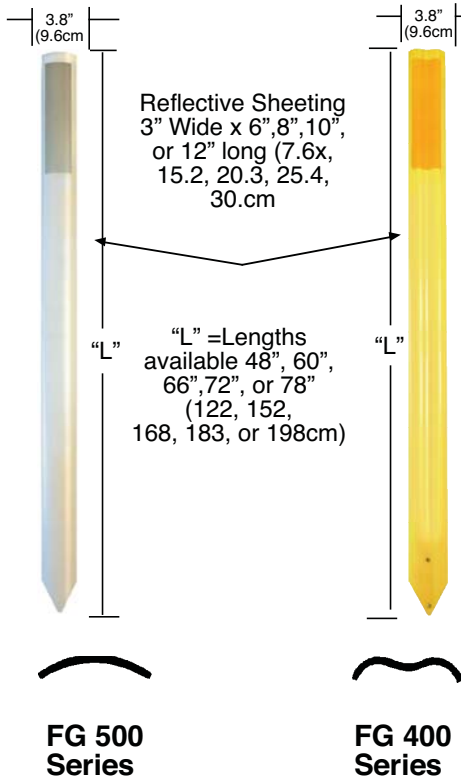

**Flexi-Guide Posts** - are available with a number of standard and special options, including reflective sheeting, message decals, custom colors and length, and various anchors.

**Reflective Sheeting** - Flexi-Guide posts may be ordered with factory-applied Engineer Grade, High-Intensity or Prismatic Super High Intensity retro-reflective sheeting. Specify type, color, and size when ordering.

**Message Decals** - Flexi-Guide posts may be ordered with factory-applied Message Decals, such as "Buried Cable - Do Not Dig!" Call for details regarding availability of standard decal and custom print options.

**Custom Colors and Lengths** - Standard Flexi-Guide colors are White, Yellow, and Grey. Other colors are available on a special order basis. Flexi-Guide Posts can be cut to any length you desire.

**Anchors** - Flexi-Guide posts may be supplied with or without plastic or steel anchors. If anchors are required, specify either plastic or steel when ordering.

## Flexi-Guide Anchors

FG 95  
Plastic Anchor  
all purpose

FG 96  
Steel Anchor  
for more  
challenging soils

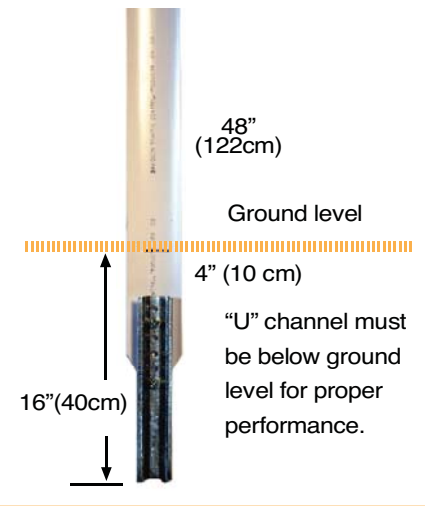

Davidson Traffic Control Products

"Creating Products to Save Lives"



# Options and Applications Flexi-Guide® 400 & 500

Flexible Roadside Delineator Posts

- Drivable flexible guide posts for roadside delineations.
- Recycled engineering polymers withstand repeated impacts.
- Guide posts that offer a combination of strength, flexibility and durability that stands up in the harshest weather conditions.
- They will not discolor when exposed to UV rays and will not rust, rot or splinter.
- The FG 400 & 500 posts can be cut to any length; there are three standard colors: white, yellow and gray, other colors are available.
- The FG 500 provides maximum display area for vertical messages that comply with US DOT specifications are available and can be applied at the factory.
- NTPEP Tested, NCHRP 350 Approved.
- Constructed of Recycled Plastics.
- Reflective sheeting option for better visibility.



 Davidson offers free downloadable CAD drawings and specifications from our website. Contact your local sales representative or email: [hwysales@pexco.com](mailto:hwysales@pexco.com) for details



Davidson Traffic Control Products

*"Creating Products to Save Lives"*

3110 70th Avenue East • Tacoma, WA 98424 / (877) 335 4638  
e-mail: [hwysales@pexco.com](mailto:hwysales@pexco.com) • [DavidsonTraffic.com](http://DavidsonTraffic.com)

